

GL6 manual

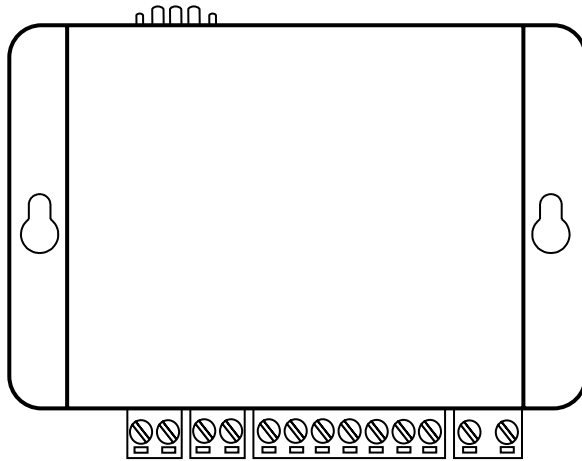

Technical data

Power:	230 VAC, 50 Hz, max 9 W
Battery:	12 V, 0.8 Ah
Inputs:	10-30 VDC, 5 mA optically isolated
Antenna connector:	SMA (female)
Size:	96 x 145 x 58 mm (H x W x D) (without antenna)
Weight:	830 g
Relay output:	1 A/30 VDC, potential free relay contact output
IP code:	IP20
Output:	12 VDC maximum output 120 mA continuous, 500 mA max 10 min
Output indicator intercom:	12 VDC, max 100 mA
Line voltage:	48 VDC
USB:	USB mini 2.0
Interface board:	<p>*IF-BOARD-4G</p> <ul style="list-style-type: none">- Micro SIM, 15 x 12 x 0,71 mm- Supports 2G, 3G and 4G (800/900/1800/2100/2600 MHz)- Requires SW 1.30 or later <p>*IF-BOARD-NIF</p> <ul style="list-style-type: none">- Nano SIM, 12,3 x 8,8 x 0,67 mm- Supports 2G, 3G and 4G (800/900/1800/2100/2600 MHz)- Requires SW 1.42 or later
	The product is intended for use in EMEA countries.
Operating temperature:	+5 - 40C
Air humidity:	30 - 90 % RH

Content

General information	4
Introduction	5
Overview	5
Wiring diagram	6
Emergency light	7
Relay output	7
Intercom	8
Network services	9
Activating the SIM card	9
Activate Ethernet port	10
Indication LED	11
GSM field strength	11
Reset button	11
Configuration	12
Configuration with PC	12
SafeLine Pro	12
Operation	17
Troubleshooting	18
Interference/poor sound quality	18
Avoid GSM interference	18

General information

This unit was built with state-of-the-art technology and to generally recognised safety related technical standards currently applicable. These installation instructions are to be followed by all people working with the unit, in both installation and maintenance.

It is extremely important that these installation instructions are made available at all times to the relevant technicians, engineers or servicing and maintenance personnel. The basis prerequisite for safe handling and trouble free operation of this system is a sound knowledge of the basic and special safety regulations concerning conveyor technology, and elevators in particular. The unit may only be used for its intended purpose. Note in particular that, no unauthorised changes or additions may be made inside the unit or individual components.

Exclusion of liability

The manufacturer is not liable with respect to the buyer of this product or to third parties for damage, loss, costs or work incurred as a result of accidents, misuse of the product, incorrect installation or illegal changes, repairs or additions. Claims under warranty are likewise excluded in such cases. The technical data is the latest available. The manufacturer accepts no liability arising from printing errors, mistakes or changes.

Declaration of conformity

Download "The declaration of conformity" at our website: www.safeline-group.com

Safety Precautions!

- Only trained professionals, who are authorised to work on the equipment, should install and configure this product.
- This quality product is dedicated for the lift industry. It has been designed and manufactured to be used for its specified purpose only. If it is to be used for any other purpose, SafeLine must be contacted in advance.
- It should not be modified or altered in any way, and should only be installed and configured strictly following the procedures described in this manual.
- All applicable health and safety requirements and equipment standards should be considered and strictly adhered to when installing and configuring this product.
- After installation and configuration this product and the operation of the equipment should be fully tested to ensure correct operation before the equipment is returned to normal use.

Electrical and electronic products may contain materials, parts and units that can be dangerous for the environment and human health. Please inform yourself about the local rules and disposal collection system for electrical and electronic products. The correct disposal of your old product will help to prevent negative consequences for the environment and human health.



Introduction

Overview

SafeLine GL6 is a line emulator that simulates a standard telephone line. It can be used together with all SafeLine telephones or any other PSTN (Public Switched Telephone Network) telephone. Easy to install and suitable as both temporary or permanent installation.

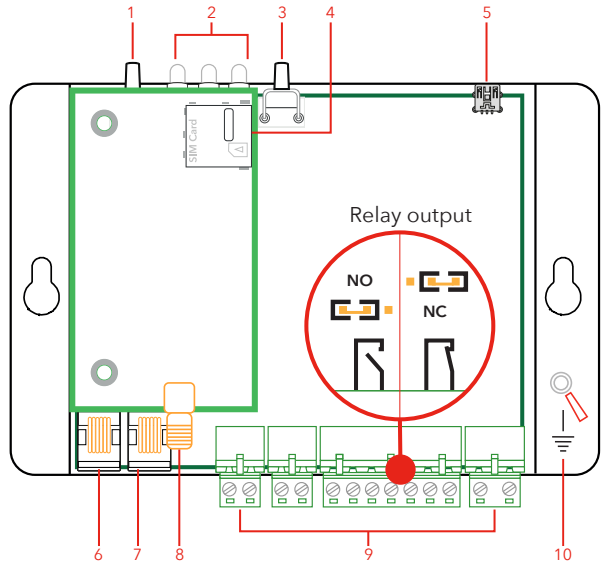

1. Reset button
2. LED's
3. Intercom button - press once to activate an intercom call
4. SIM-card holder
5. USB-mini for configuration with SafeLine Pro
6. RJ12 for intercom (comphone)
7. RJ12 for telephone line
8. SMA-antenna connector
9. Terminals
(C3: Lift Monitoring System (LMS)/SMS. Programmable input for LMS to send SMS messages to up to 3 different numbers.)
10. GND

Wiring diagram

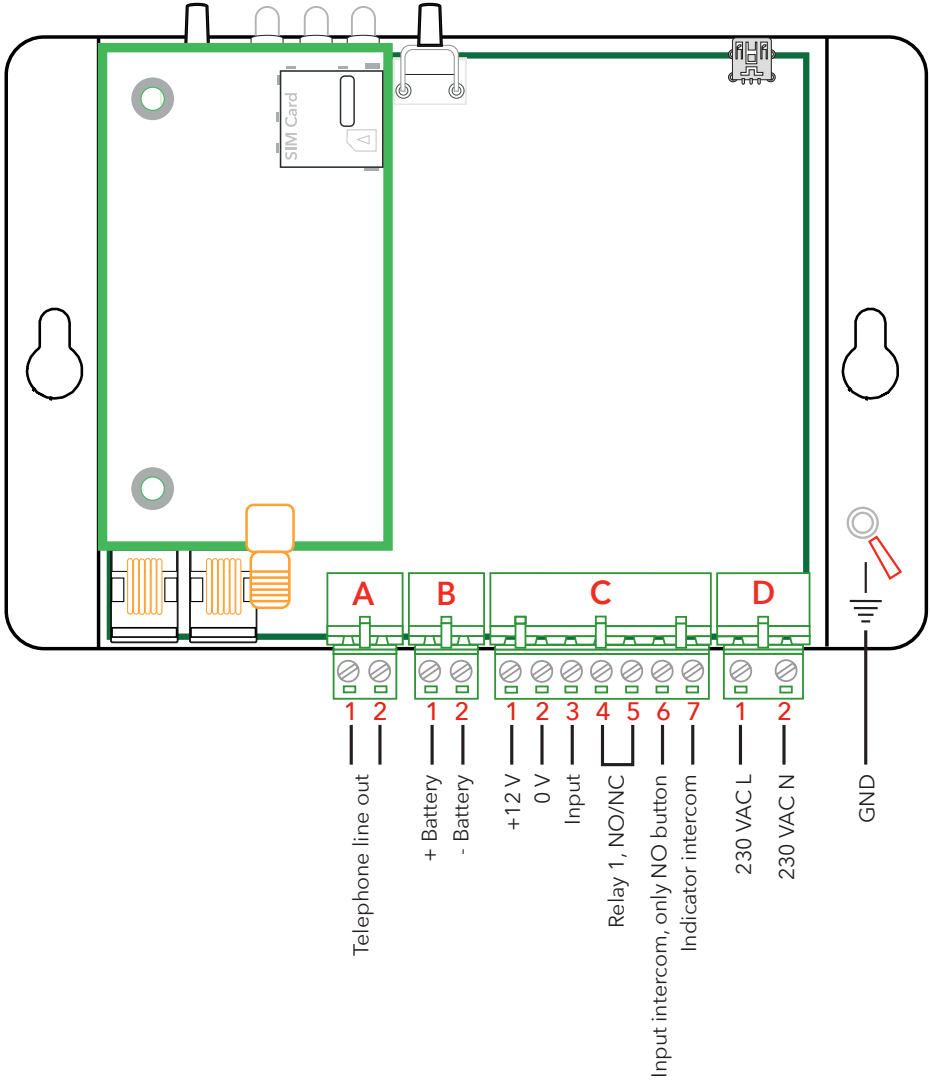

Emergency light

Relay is activated when there is a mains power failure (230 VAC).

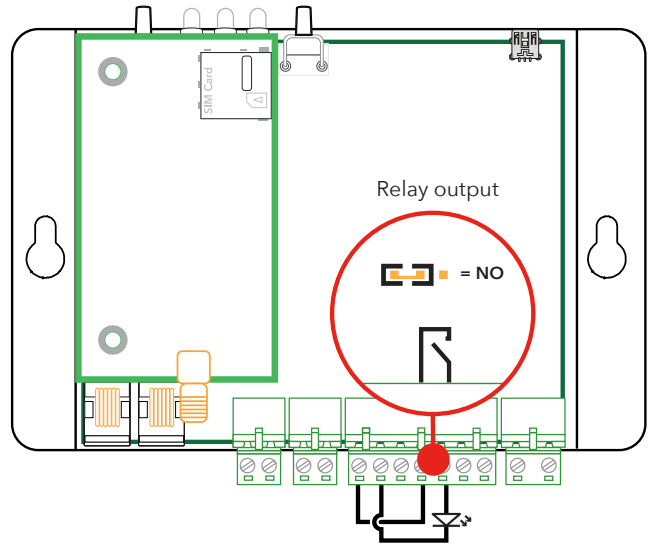

Relay output

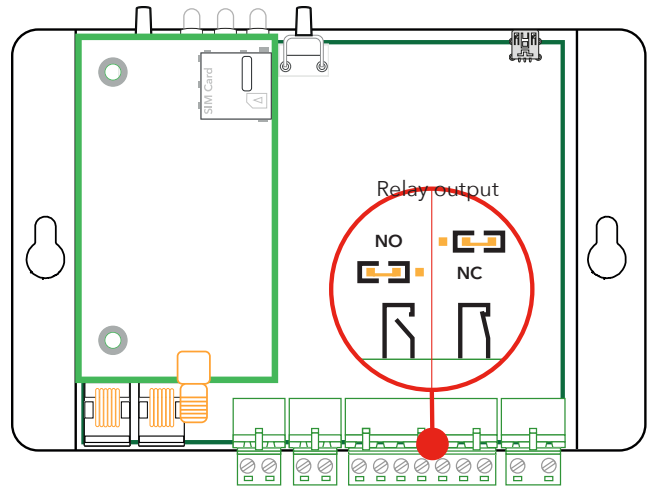

There are three ways to configure the relay output (configurable in SL Pro).

1. Battery failure

Relay is active when battery test has failed.

2. System failure

Relay is active when GL6 has GSM network coverage. Relay deactivates when GSM network is missing for more than 15 seconds or when mains power has been off for more than 15 minutes.

3. Emergency light

Relay is activated when there is a mains power failure (230 VAC).

Intercom

Maximum call time is 5 minutes. After that, the call will be disconnected. To cancel an intercom call, press #.

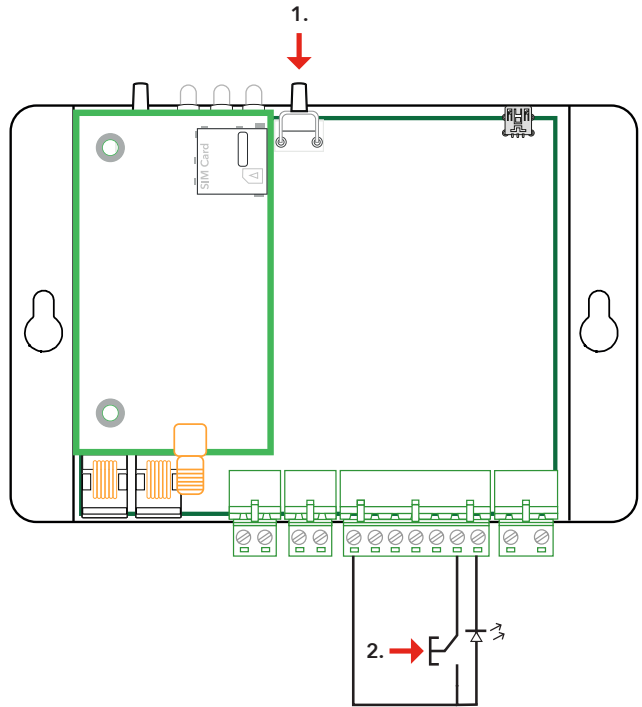

The intercom function can be triggered in two ways:

1. Push button once to activate intercom.
2. Push NO button to activate intercom.
Optional external indication of active intercom function can be wired between 12 VDC output and intercom indication output.

Use of intercom

When an intercom call is generated the GL6 rings up to 16 times, waiting for a phone that is connected to the GL6 to answer. LED3 indicates when a ringing call expires, and when the call time counter is activated. LED3 is activated as long the call is on. Maximum call time is 5 minutes (not adjustable).

Hash, "#", must be generated for the phone to disconnect the call.

Network services

Only applicable for *GL6 and *GL6-FC: Before you can start using a new SIM card, the card has to be prepared and support 2G network. Cards that only support 3G and/or 4G will not function.

Only applicable for *GL6-4G and *GL6-FC-4G: Network services may differ from country to country and/or service providers. Contact your service provider for more information about 4G and VoLTE in your specific region.

Activating the SIM card

Disconnect both mains and battery plugs, before inserting or removing the SIM card.

The GL6 can only recognize the PIN code if the code is set to "1234", "0000", "1111" or if it is deactivated. If set to anything else, the GL6 cannot use the SIM card.

If the PIN code is set to "1234", "0000" or deactivated, the SIM card can be used on any of SafeLine's GSM products.

Setting the PIN code

1. Insert the SIM card in an ordinary phone. In the phone's security settings, change the PIN to "1234". If not possible, set the PIN code to "0000" or, if available, set the "PIN code request" option to "OFF".
2. Verify the PIN code by switching your phone off and on again.
3. Make a call from your phone to verify that the SIM card is active.
4. Make a call to the GL6 after insertion to ensure there is a proper connection.

"1111" PIN code

If the PIN is set to "1111", the code will be randomly generated by the SafeLine GSM unit and memorized. This is a safety measure, making sure the SIM card will only work with the selected SafeLine GSM unit. To change the PIN again, use the PUK code provided to you by your mobile services provider for setting up a new PIN.

If you want to upload a new SIM card for the GSM unit with a new "1111" PIN, you will first need to upload a SIM card with PIN code "1234" or "0000" to clear the old code in memory.

Activate Ethernet port

NIF (Network Interface)

The Ethernet port can be activated using the Lynx App:

1. In the Lynx App: Go to Konfiguration, and activate NIF.

Note! By activating this parameter, you acknowledge and agree that SafeLine are not responsible for any data generated, stored, or processed. You assume full responsibility for any consequences that may arise from its use. Furthermore, SafeLine are not responsible for the amount or volume of data generated. The cost associated with the volume of data is the responsibility of the customer and not SafeLine. Additionally, SafeLine takes no responsibility regarding cybersecurity risks or breaches associated with any connected device.

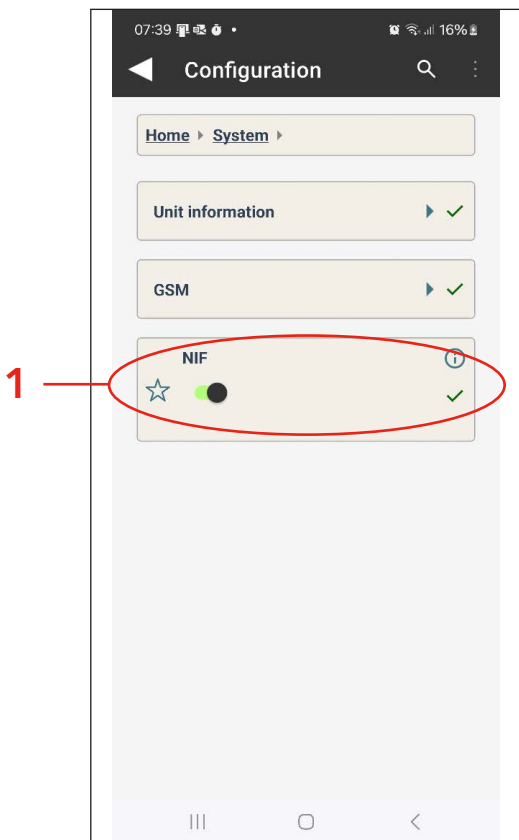

Indication LED

LED 1 indicates the power supply status:

Continuous green		Mains power supply OK.
Flashing red		Battery operated, no main power supply.

LED 2 indicates battery condition:

Light off		Battery OK.
Flashing red		Battery check in progress.
Continuous red		Battery test failure.

LED 3 indicates the phone line's status:

Slowly flashing green		GSM network OK.
Flashing green		Call connection in progress.
Flashing two times green		Connected handset is not hung up.*
Continuous green		Call connected.
Flashing yellow		Incoming call.
Flashing red		Searching for GSM network.
Continuous red		No SIM card.

* Hash, "#", must be generated for the phone to disconnect the call.
Please ask the operator to press "#" before hanging up.

GSM field strength

If the reset button on the unit is pressed for 3 seconds the GSM field strength will be displayed for 5 seconds.

LED	GSM signal strength
1 2 3	
	= 100 %
	>= 85 %
	>= 70 %
	>= 55 %
	>= 30 %**
	>= 15 %
	>= 0 %

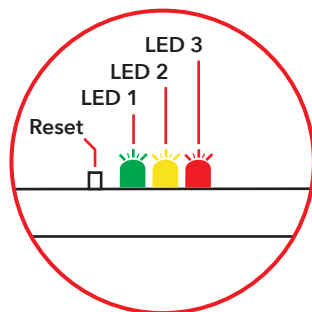

** Minimum signal strength for using GSM Interface

Reset button

Reset button

Press for 5 sec	Turn off when using battery power
Press for 3 sec	Check GSM network signal strength
Press 3 times	Start a battery test manually
Press once	Cancel battery test
Press once	Turn on when using battery power

Configuration

Configuration with PC

The unit can be configured at the office prior to the installation or on site after installation.

The configuration software SafeLine Pro can be downloaded from www.safeline-group.com.

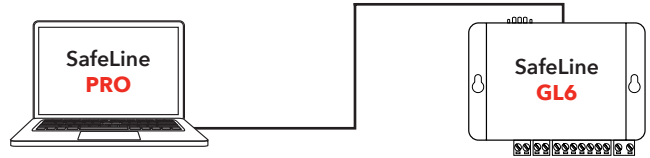

SafeLine Pro

Use the latest version of SafeLine Pro. The software can be download from www.safeline-group.com.

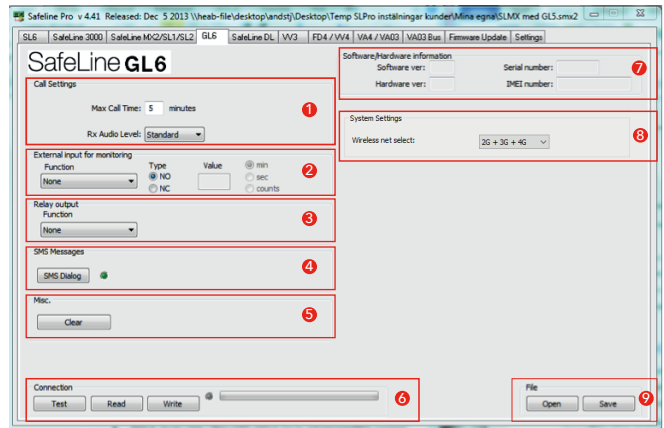

1. Call settings

- **Max call time**

Here you can choose the maximum call time between 1-99 minutes.

0 = Unlimited call time.

5 = Default value.

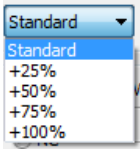

- **RX audio level**

Received Audio Level:

Standard.

Increase on the RX level of the receiver by 25%.

Increase on the RX level of the receiver by 50%.

Increase on the RX level of the receiver by 75%.

Increase on the RX level of the receiver by 100%.

Note: Large increase may cause voice switching problems.

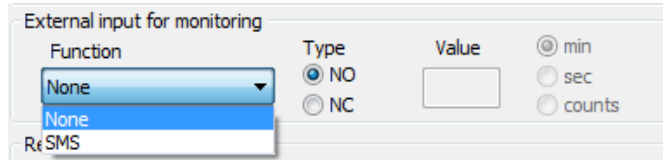

2. External input for monitoring

- **Function**

Here you can set the input to different functions.

None: Input 1 is not enabled (default).

SMS: Sends a text message when the input has reached the set value.

- **Type**

Sets the input to N/O (Normally open) or N/C (Normally closed) linked.

- **Value**

Sets the input activation time.

E.g. 10 min, 10 sec or 10 pulses before activating an event.

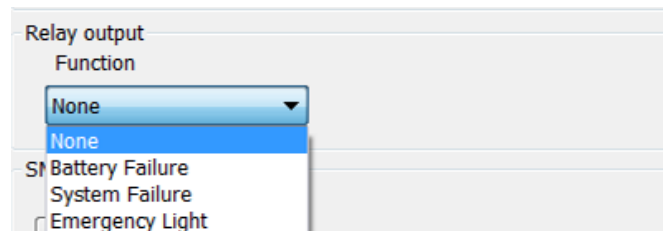

3. Relay output

Sets the output relay operating mode.

- **None**

The output relay is not enabled (default).

- **Battery failure**

The output relay is activated if the battery test has failed.

- **System failure**

The output relay is activated when the GL6 has a GSM network.

The output relay is deactivated when the GSM network has been lost for more than 15 seconds, or when the power has been off for more than 15 minutes.

- **Emergency light**

Relay is activated when there is a main power failure, and switches to battery power.

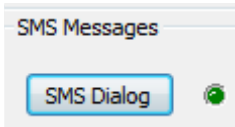
A configuration interface for SMS messages. It contains three sections: "Battery Failure SMS", "Mains Failure SMS", and "LMS Input SMS". Each section has three input fields for "SMS Destinations" (labeled 1, 2, and 3) and a text area for the "Message" (with a "max 128 characters" limit). A "Done" button is located at the bottom right.

4. Text message

Here you can enter information and specify the destination of the text message.

- **Battery failure SMS**

If the battery test fails, a text message is sent.

SMS destination: you can enter up to 3 mobile phone numbers.

Message: the limit for the message text is 128 characters maximum. E.g.: "The battery test has failed at..."

- **Mains failure SMS**

A text message is sent if the 230 VAC supply has been lost for more than 15 minutes.

SMS destination: you can enter up to 3 mobile phone numbers.

Message: the limit for the message text is 128 characters maximum.

- **LMS input SMS**

An text message is sent if the LMS input has reached the set value.

SMS destination: you can enter up to 3 mobile phone numbers.

Message: the limit for the message text is 128 characters maximum.

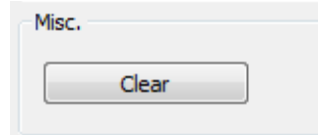

5. Miscellaneous

Resets all input fields to their default value. Puts SafeLine Pro in basic mode execution, empties phone fields etc.

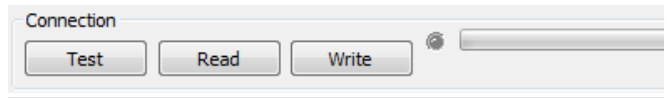
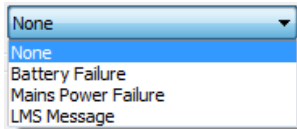

6. Connection

Test

With a computer directly to GL6.

- **Alarm type**

None: no test alarms activated.

Battery failure: simulates a battery test

Mains power failure: simulates a power failure.

LMS message: simulates an operational alarm failure.

- **Functions**

LMS input: lights green when the input is active.

Intercom input: lights green when the intercom is activated.

GSM net: lights green when there is enough network coverage.

Mains power: lights green when the input is active.

Relay output: toggles the output relay on and off.

Intercom output: toggles the intercom output on and off.

Line output active: lights green when the line output is active.

Read

Reads out the configuration of the GL6.

Write

Write changes to the GL6.



Software/Hardware information

Software ver:	<input type="text"/>	Serial number:	<input type="text"/>
Hardware ver:	<input type="text"/>	IMEI number:	<input type="text"/>

7. Software / hardware information

- **Software version**
Here you can find information about the GL6 software version.
- **Hardware version**
Here you can find information about the GL6 hardware version.
- **Serial number**
Here you can find the serial number of the GL6.
- **IMEI number (International Mobile Equipment Identity)**
The IMEI is used by the GSM and UMTS mobile phones. The IMEI is used by the GSM network to identify and authorize mobile phones, and can thus stop the stolen mobile phones and make them unusable.

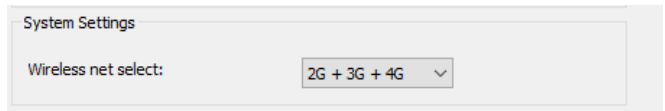

System Settings

Wireless net select:

8. System settings

Depending on network module, select the wireless net.

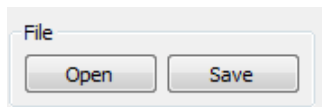

File

9. File

Open a previously saved GL6 parameter file, or save the current GL6 parameters to a file. E.g. IDD12345678.gl6. Save the GL6 parameter file for use elsewhere, for example if you have several GL6 with the same settings.

Operation

Use the latest version of SafeLine Pro. The software can be download from www.safeline-group.com.

Battery check

- Automatic battery test

Battery capacity is tested every 7 days. The test takes 15 minutes maximum. If the battery test fails LED2 is activated. An SMS is sent to 3 destinations maximum and with a maximum of 128 characters.

- Manual battery test

Start battery test by pressing the reset button 3 times. To cancel the test press reset button once.

- Battery discharge protection

When the GL6 runs on battery power, the battery saver function will turn off the GL6 when the battery level reduces to 10.7 volts. When the mains power is reconnected the GL6 powers up again.

Mains power control

The GL6 is constantly monitoring the mains power. If power failure occurs an SMS regarding the power loss will be sent after 15 minutes. An SMS is sent to 3 destinations maximum and with a maximum of 128 characters.

External input 1 (SMS)

There is an input for monitoring with the possibility to send SMS messages. The input requires 12VDC and it is possible to choose between N/O and N/C (N/O is default). An SMS is sent to 3 destinations maximum and with a maximum of 128 characters.

GSM functions

GSM field strength indication is active for 10 seconds when it is activated by the reset button. If the GSM network coverage is lost, the GL6 will automatically restart the GSM module after 10 minutes. The GL6 provides 48 VDC line power only when it has GSM network.

Outgoing call

Maximum call time for outgoing calls is configurable in SafeLine Pro from 1 to 99 minutes (0 = unlimited). When a call is interrupted, the GL6 generates. 10 busy tones, before it returns to standby mode.

Configuration of GL6

Use the latest version of SafeLine Pro. Configuration can only be done in "standby mode". All configuration must be done using the USB port. Serial port is only for factory use.

Trouble-shooting

No LED's are lit.

- Make sure that the supply voltage is: 230 VAC

LED 3 is continuously red.

- Make sure that the SIM card is correctly inserted.
- Check that the SIM card PIN code is deactivated or that the PIN code is set to "1234", "0000" or "1111"
- Make sure that the SIM card is activated and operational by testing the card in a cellular phone.

The call is interrupted directly after being connected.

- Make sure the battery is properly charged. Check voltage with the battery plug disconnected.

Call cannot be connected. Error message from telephone operator.

- To make a call, area code must always be used.

Interference/ poor sound quality

- Bear in mind that the wiring between GL6 and the lift telephone/ phone is basically a "standard" PSTN-line and can therefore not be placed within the lift travelling cable together with high voltage. *** (Risk of interference)***
- Always place the antenna in an upward position and at least 1500 mm distance from GL6.
- Place the antenna where the highest field intensity is obtained according to the table on the unit.
- When a call is connected, try placing the antenna in different places to find where the best receiving/sending position is.

Avoid GSM interference

To avoid GSM interference: Place the unit, the lift emergency telephone and the GSM antenna at least 1500 mm apart.

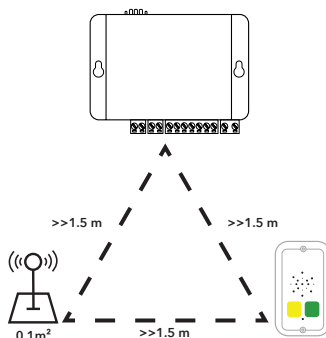

EU Declaration of Conformity

Product: Mobile network emulator
 Type / model: **Safeline GL6**
 Article no: *GL6, *GL6-4G, *GL6-FC, *GL6-FC-4G
 Manufacturer: SafeLine Sweden AB
 Year: 2020

We herewith declare under our sole responsibility as manufacturer that the products referred to above complies with the following EC Directives:

Directives

Radio Equipment (RED):	2014/53/EU
RoHS 2:	2011/65/EU

Standards applied

EN 12015:2014	EMC: Emission, Electromagnetic compatibility
EN 12016:2013	EMC/Lifts: Immunity, Electromagnetic compatibility
EN 62368-1:2014/AC:2015	LVD: Information Technology Equipment
EN 50581:2012	RoHS: Technical doc. for assessment of restriction of RoHS.

For RED 2014/53/EU, the conformity assessment procedure "Module A" used as described in Annex II. Accordingly, respective manufacturer has done the radio modules conformity assessment:

Standards applied

Article of Directive 2014/53/EU

EN 60950-1:2006+A11:2009+A1:2010+A12:2011+A2:2013

3.1 (a): Health and safety of the user

Module	Notified body	Address	NB nr	Test nr
1 GL865-Dual V3.2.	Dekra Test & Cert	Parque Tecnológico de Andalucía / SeveroOchoa 2,	1909	53051 RBN.001
LE910-EU V2	Dekra Test & Cert	29590 Spain	1909	52382 RCB.001
LE910C1-EU	Dekra Testing and Certification	Parque Tecnológico de Andalucía / Severo Ochoa 2, 29590 Málaga, Spain	1909	57536RNB.001A1

EN 62311:2008

EN 301 489-1 v2.1.1 + EN 301 489-5 v1.1.0 Draft

3.1 (B): Electromagnetic Compatibility

EN 301 511 v12.5.1

3.2: Effective use of spectrum allocated

EN 301 908-1 v11.1.1 / -2 v11.1.1 / -13 v11.1.1

Firmware used during assessment

GL865-Dual V3:	16.00.152 / 16.01.150 / 16.01.153
LE910-EU V2:	20.00.402
SafeLine GL6:	1.00

Tyresö, 2020-03-09

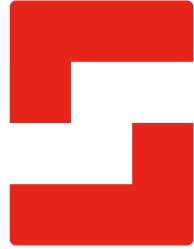

Lars Gustafsson,
 Technical Manager, R&D, SafeLine Group

**SafeLine Headquarters**

Antennvägen 10 · 135 48 Tyresö · Sweden
Tel.: +46 (0)8 447 79 32 · info@safeline.se
Support: +46 (0)8 448 73 90

SafeLine Denmark

Vallensbækvej 20A, 2. th · 2605 Brøndby · Denmark
Tel.: +45 44 91 32 72 · info@safeline.dk

SafeLine Norway

Solbråveien 49 · 1383 Asker · Norway
Tel.: +47 94 14 14 49 · post@safeline.no

SafeLine Europe

Industrieweg 114 · 3980 Tessenderlo-Ham · Belgium
Tel.: +32 (0)13 664 662 · info@safeline.eu
Support: +32 (0)4 85 89 08 95

SafeLine Deutschland GmbH

Kurzgewannstraße 3 · D-68526 Ladenburg · Germany
Tel./Support: +49 (0)6203 840 60 03 · sld@safeline.eu

SafeLine Group UK

Unit 47 · Acorn Industrial Park · Crayford ·
Kent · DA1 4AL · United Kingdom
Tel.: +44 (0) 1322 52 13 96 · info@safeline-group.uk

SafeLine is a registered trademark of SafeLine Sweden AB. All other trademarks, service marks, registered trademarks, or registered service marks are the property of their respective owners.