

FD1600 manual

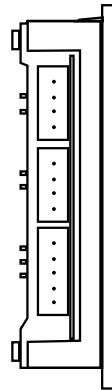
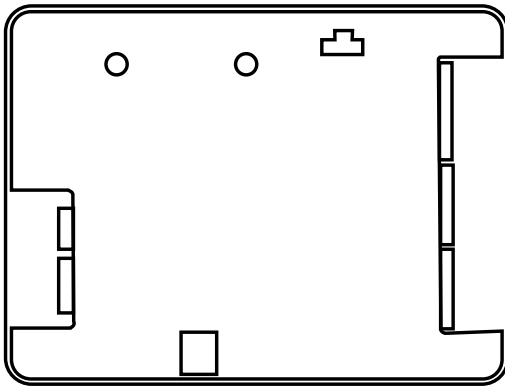

Technical data

External power:	18-28 VDC
Power consumption:	40-200 mA at 24 VDC
CAN:	Fixed speed 125 kBit/s Up to 63 floor units (plus two car units, and one system unit). One CANopen compliant absolute encoder.
Inputs / Outputs:	8 Inputs and 1 Output Inputs: 24 V / 0 V
Memory card:	microSD card, SD and SDHC (up to 32 GB) with soundfiles
Speaker output:	3W 8Ω
Size:	80 x 61 x 20 mm (H x W x D)
Operating temperature:	+5° C – +40° C
Orientations:	0°, 90°, 180° or 270°
Inputs:	Decimal, binary, gray, IPS, absolute encoder
Matrix:	10 rows x 16 columns
Color:	Red, blue
Bluetooth:	Bluetooth 4.0 BLE 2,4 GHz
Audio files:	Format WAVE-8 or 16kHz, 16 bit mono, max 16 sec/file

Content

General information	4
Overview	5
System description	5
LED indicators & component list	6
Installation	7
Inputs	7
Wiring diagram FD1600	8
Wiring diagram FD1600 - IPS	10
Start-up	12
Menu buttons	13
Menu tree structure	14
Floor texts	17
Display fonts	17
Arrows	18
Boot menu	20
Setup menu	20
Configuration	21
Learning mode with IPS	21
Dynamic menus	21
Memory card	21
Sound files	22
Checklist before deployment of IPS and FD1600	22
Declaration of Conformity	23

General information

This unit was built with state-of-the-art technology and to generally recognised safety related technical standards currently applicable. These installation instructions are to be followed by all people working with the unit, in both installation and maintenance.

It is extremely important that these installation instructions are made available at all times to the relevant technicians, engineers or servicing and maintenance personnel. The basis prerequisite for safe handling and trouble free operation of this system is a sound knowledge of the basic and special safety regulations concerning conveyor technology, and elevators in particular. The unit may only be used for its intended purpose. Note in particular that, no unauthorised changes or additions may be made inside the unit or individual components.

Exclusion of liability

The manufacturer is not liable with respect to the buyer of this product or to third parties for damage, loss, costs or work incurred as a result of accidents, misuse of the product, incorrect installation or illegal changes, repairs or additions. Claims under warranty are likewise excluded in such cases. The technical data is the latest available. The manufacturer accepts no liability arising from printing errors, mistakes or changes.

Declaration of conformity

Download "The declaration of conformity" at our website: www.safeline-group.com

Safety Precautions!

- Only trained professionals, who are authorised to work on the equipment, should install and configure this product.
- This quality product is dedicated for the lift industry. It has been designed and manufactured to be used for its specified purpose only. If it is to be used for any other purpose, SafeLine must be contacted in advance.
- It should not be modified or altered in any way, and should only be installed and configured strictly following the procedures described in this manual.
- All applicable health and safety requirements and equipment standards should be considered and strictly adhered to when installing and configuring this product.
- After installation and configuration this product and the operation of the equipment should be fully tested to ensure correct operation before the equipment is returned to normal use.

Electrical and electronic products may contain materials, parts and units that can be dangerous for the environment and human health. Please inform yourself about the local rules and disposal collection system for electrical and electronic products. The correct disposal of your old product will help to prevent negative consequences for the environment and human health.



Overview

System description

Each unit must be programmed with a unique unit ID (unit address) and a working mode. Also assure that only one unit control the floor position.

FD1600 is a system consisting of floor and car displays. The system is wired together via CAN bus.

The floor position information can be set directly at the unit's input or from external source. External source can be a hardwired absolute encoder or a hardwired position unit.

The FD1600 unit system may contain:

- Floor unit (up to 63 floors)
- Car unit (up to 2 units)
- System unit (none or 1 unit)
- External position unit (none or 1 unit)

It is also possible to use only one display without any connection to the CAN bus (standalone).

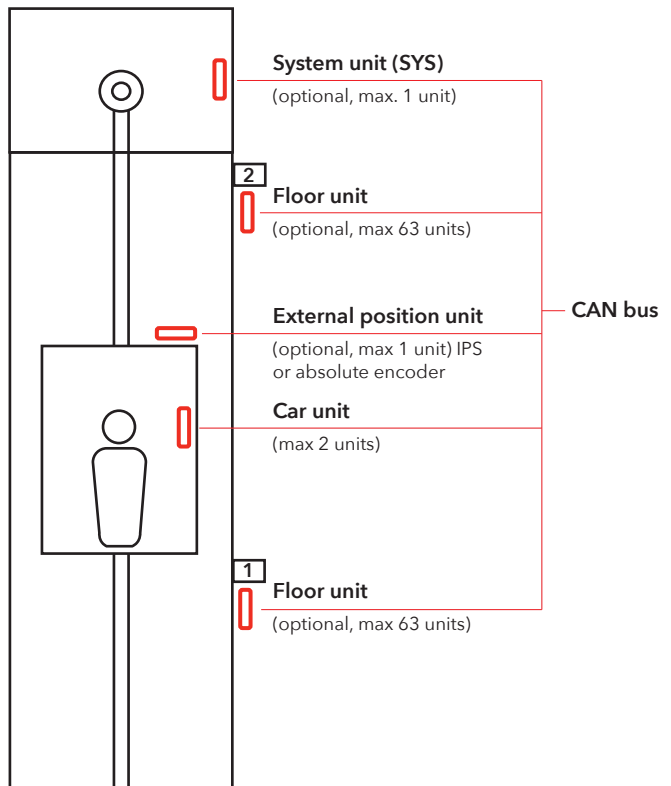

LED indicators & component list

All connections have to be in place before powering up the installation. Changes in the wiring with a powered installation is not allowed.

LED

a	Green USB LED	Constantly lit when a USB-cable is connected.
b	Green CAN BUS detect	Flashing when valid CAN message detected.
c	Red CAN BUS error	Lit or flashing when BUS error detected (auto recovery).
d	Yellow SD LED	Constantly lit (for 2 minutes) when SD card is inserted and working. After 2 minutes the LED-indicator turns off.
e	Green power	Constantly lit when powered up.

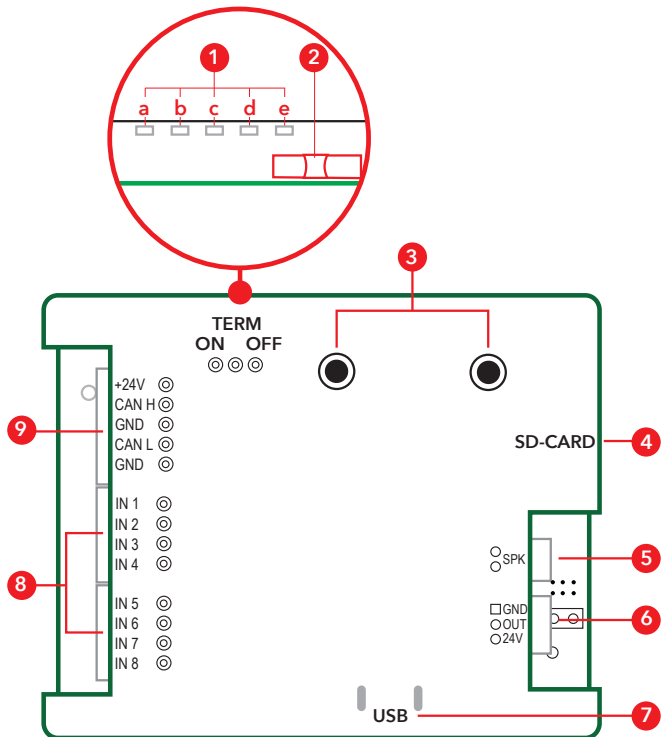

1. LED indicator.
 - a. USB cable connected
 - b. CAN BUS
 - c. CAN BUS error
 - d. SD card
 - e. Power
2. Termination switch
3. Menu buttons.
4. SD card slot.
5. Output for speaker.
6. Output (no function).
7. USB outlet for configuration and SW update.
8. Input for decimal, binary and gray.
9. Input for power and CAN BUS connection.

Installation

Inputs

FD1600 can handle different signals from a controller, these can be sourced from +24 VDC or 0 VDC.

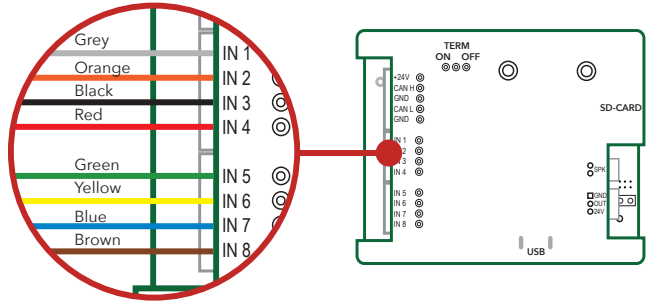

Binary signals

Binary code is a standardized way to control outputs that are used for floor displays.

Default binary inputs (for 15 floors)

Input 1	Binary 1	Input 5	Programmable
Input 2	Binary 2	Input 6	Programmable
Input 3	Binary 4	Input 7	Programmable
Input 4	Binary 8	Input 8	Programmable

Gray code signals

Gray code is an uncommon way to control floor displays. You only change one input at a time, which minimizes the risk of error. It is often used on older controllers.

Default gray code inputs (for 15 floors)

Input 1	Gray code 1	Input 5	Programmable
Input 2	Gray code 2	Input 6	Programmable
Input 3	Gray code 3	Input 7	Programmable
Input 4	Gray code 4	Input 8	Programmable

Decimal signals (one-floor-per-pin)

The old way to control floor displays are called decimal or one-floor-per-pin.

Default decimal inputs (floor 1-8)

Input 1	Floor 1	Input 5	Floor 5
Input 2	Floor 2	Input 6	Floor 6
Input 3	Floor 3	Input 7	Floor 7
Input 4	Floor 4	Input 8	Floor 8

Default decimal inputs (floor 9-16)

Note: two FD1600 units need to be installed to address floors 9-16

Input 1	Floor 9	Input 5	Floor 13
Input 2	Floor 10	Input 6	Floor 14
Input 3	Floor 11	Input 7	Floor 15
Input 4	Floor 12	Input 8	Floor 16

Wiring diagram FD1600

Binary, decimal and
gray decoding

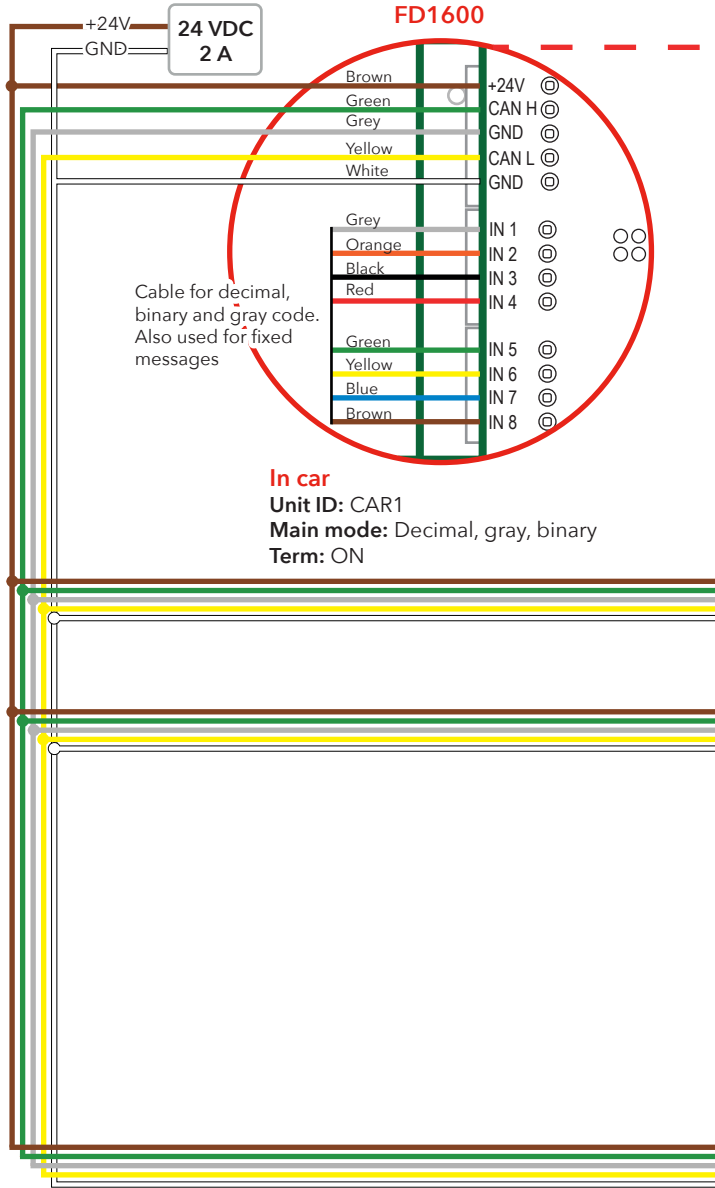

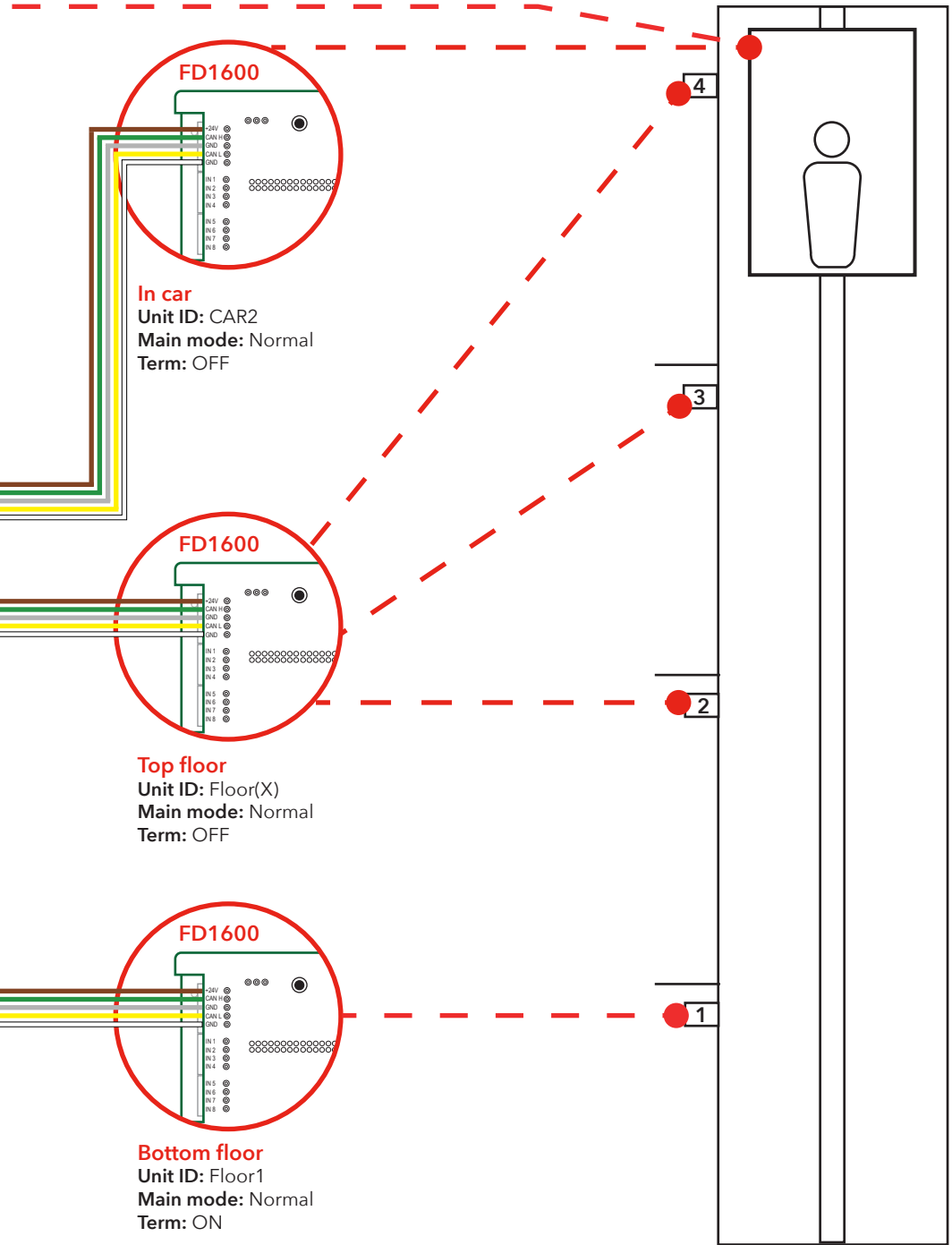

FD1600

In car
 Unit ID: CAR2
 Main mode: Normal
 Term: OFF

FD1600

Top floor
 Unit ID: Floor(X)
 Main mode: Normal
 Term: OFF

FD1600

Bottom floor
 Unit ID: Floor1
 Main mode: Normal
 Term: ON

4

3

2

1



Wiring diagram FD1600 - IPS

Wiring diagram for car unit
and/or floor units.
IPS

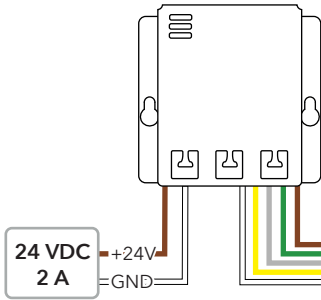

Install IPS on car roof

Term: On

Note! If only one display is connected set Term to on.

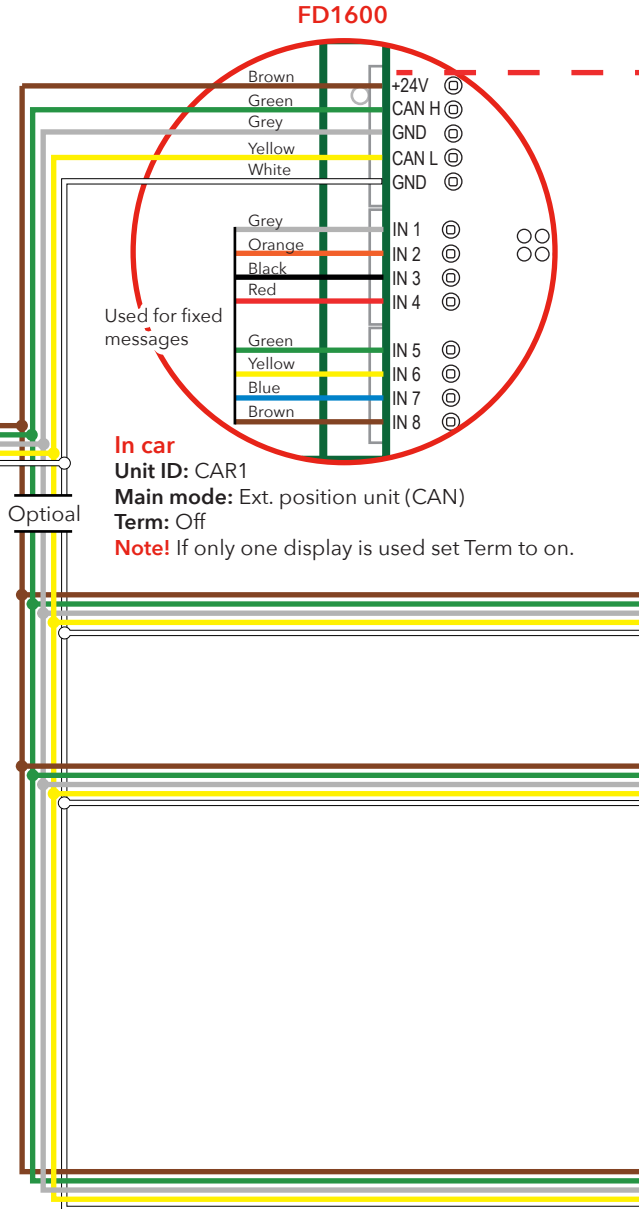

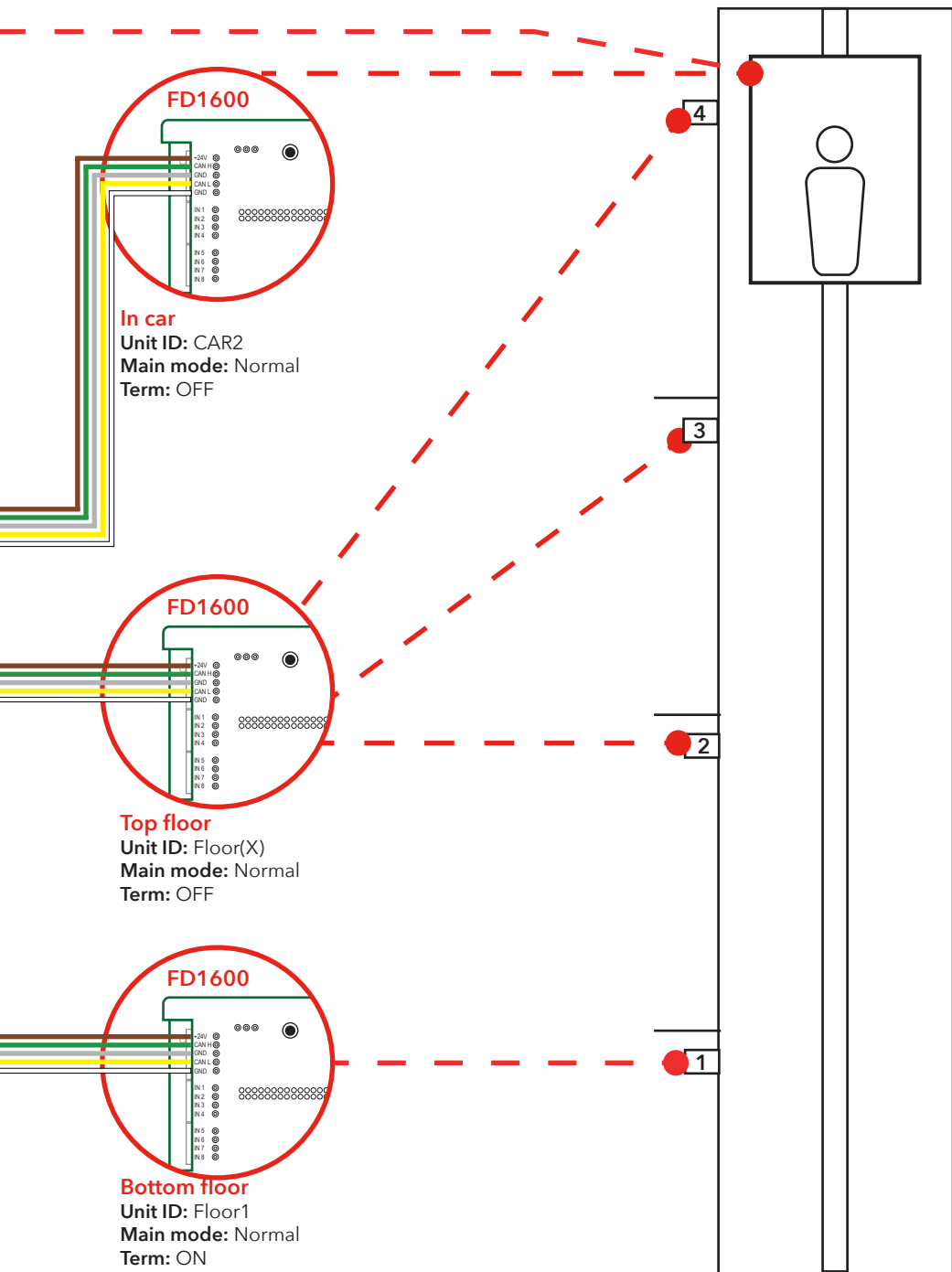

Start-up

If no floor trigger is received or generated, the display shows the user settable error text. This text may also be a symbol (i.e. the STOP symbol).

The display starts "empty" with no text on the display. After internal initialization, functionality starts and sends status for any active inputs to other connected display.

If a speaker is connected it is possible to hear the start-up sound.

- No sound = no memory card inserted or recognized
- Two short beeps = memory card recognized and usable
- One long beep = memory card inserted, but unusable (try removing and re-insert)

Error codes

When an exception or internal fault is detected, the display shows an error code. The error code is always two characters, starting with the full stop punctuation mark ".".

The following error codes are defined

.0	undefined error
.1	more than one unit is set as floor generator
.2	a unit with same ID exists *
.3	main mode not set (or out of bounds)
.4	position too high
.5	position too low
.6	no positions set (or learned)
.7	ID not valid (out of bounds) *
.8	encoder heartbeat fault (encoder lost)
.T	IPS not ready for learning trip.
.A	program mode active.

* If conflicting ID's one or more units may exist with same ID. All ID's must be unique, and it is up to the installer to ensure the system integrity. When these errors are detected, a reset or power cycle must be performed to clear the error.

CAN bus

CAN bus speed is fixed at 125 kBit/s. The CAN BUS must be terminated in each end. When the bus is active and connected, two units have enabled the termination. All other units connected to the bus have termination disabled. If a CAN absolute position encoder or an external CAN position unit (i.e. IPS unit) is used, also check and set bus termination of these units.

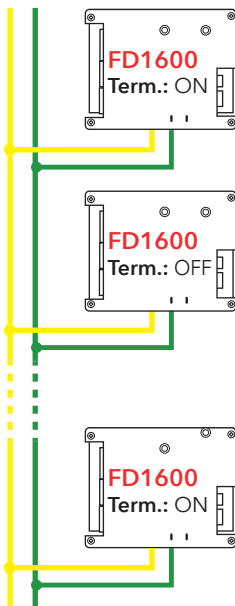

Fig. 1

Menu buttons

The SLProFD1600 need to be used in order to access all of the installation options.

Download SafeLine Pro from: www.safeline-group.com via the SafeLine Pro product page

There are two menu buttons, which are located on the back of the unit.

Using the menu buttons

Pressing the two menu buttons simultaneously will:

- Enter configuration mode, or
- Confirm selection.

Pressing one of the menu buttons at a time will:

- Scroll through the current menu options.
The menu options will be presented and loops around either clockwise (if pressing the right menu button) or counterclockwise (if pressing the left menu button).

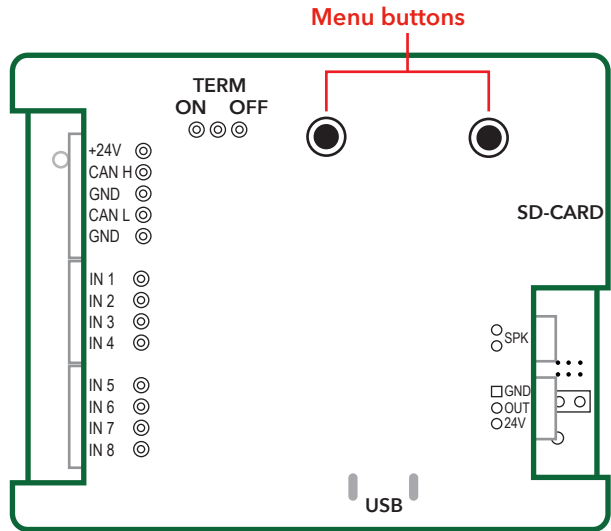

Menu tree structure

Display

DISP

Brightness

Sets the display brightness when showing text in the display.

↳ 1-20

Orientation

Sets the orientation mode, where "0" is landscape mode. The menu is always shown in same way, regardless of the settings in the orientation.

↳ 0, 90, 180, 270

Volume

Sets the speaker volume when playing WAVE-files and/or built in system sounds.

↳ 1-20

Language

Selected language sets the displayed fixed system messages. The language in the menu is fixed, and always English.

↳ ENG, GER, FRE, SWE, DAN, USR
(user language)

UNIT*

Main mode

↳ E-CA: External (IPS)

↳ E-BL: External position encoder with BLE

↳ NRM: Normal (not floor generator)

↳ DEC1: Decimal (floor 1 - 8)

↳ DEC2: Decimal (floor 9 - 16)

↳ BIN: Binary

↳ GRY: Gray code

↳ CAN: CAN Encoder

Floor count (total)

↳ 1-63

ID Unit (installation)

Sets the installation point of the unit. All units connected to the BUS must have unique ID's (two SYS or two CAR1 units are not allowed).

↳ CAR1, CAR2, Floor 1-63, SYS (System)

Arrival trigger

↳ SLW: CAR reduce

↳ STP: CAR stop

↳ NON: None

↳ INP: Input

↳ FLR: Floor change

↳ ARW: Arrow change

Arrival sound

↳ NON: none

↳ 3T: Three tone

↳ EN: EN81-70 (according to regulations)

↳ WAV: Wave

Menu tree structure

Text**



Note! Only available if Main mode and ID unit is chosen

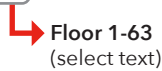

Only accessible if main mode is NOT set to "Normal". In this menu select the floor to change its text. Press both buttons, and first character of the floor text flashes. Adjust the character, and press both buttons again. Now the next character flashes. Editing is ended if an empty character is selected or three character are entered. Each time a floor text is ended, it is possible to select a new floor. Return to main menu by pressing both buttons for 2 seconds.

Input

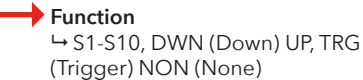
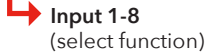

(Only accessible if not all inputs are predefined. That is for example if floor count is set to 8, "Unit > Main Mode" is set to "Decimal" and all inputs are predefined as individual floor generators.) Each time an input function is selected, it is possible to select a new input. Return to main menu by pressing both buttons for 2 seconds.

Learn***



(Only accessible if "Unit > Main Mode" is set to "CAN Encoder" or "External".) Floor 1 is always the lowest floor. "ENTER" stores encoder position for selected floor. The learning process must ALWAYS be in correct sequence 1 -> 2 -> 3 and up to maximum floor position. Learning sequence is canceled by holding both buttons for 2 seconds. Encoder resolution is only accessible if encoder is selected as "main mode".

Menu tree structure



(Turn menu off and return to normal operation. Choose if parameter must be saved.)

Default settings

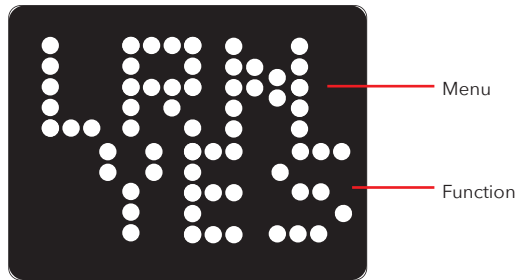

* Sub menu items change, depending on the selected "Main Mode"

** Each time a floor text/Input function is entered, it is possible to select a new floor. Return to main menu by pressing both buttons for 2 seconds.

*** Floor 1 is always the lowest floor. "ENTER" stores encoder position for selected floor. The learning process must ALWAYS be in correct sequence 1 > 2 > 3 and up to maximum floor position. Learning sequence is cancelled by holding both buttons for 2 seconds. Encoder resolution is only accessible if encoder is selected as "main mode".

Floor texts

The fixed messages always show the complete text, even if the input that triggered the text is inactive before text has rolled minimum one round.

Floor texts are user programmable and holds up to 4 characters.

Long floor text

If a long text is wanted, a user message can be assigned and used as a floor text. Write “!1” to “!10” in the floor text field, and write the desired text in the according user text field.

Symbol instead of text

It is also possible to get some fixed symbols instead of floor text. Following symbols are defined:

“!E0” Not in use
“!E1” STOP sign
“!E2” Not in use
“!E3” Not in use
“!E4” Not in use
“!E5” symbol “1/2”
“!E6” symbol “2/3”
“!E7” symbol “3/4”
“!E8” symbol “4/5”

Fixed messages

Fixed messages are handled as one, but actually divided in two parts. First part (and highest priority) is the system messages. System messages are fixed and cannot be changed. System messages automatically change depending on the selected language.

Second part is the user messages and is set up via external programming tool. It is also possible to select if message has to roll once in display, or it has to be active as long as the input is activated. Highest priority is “System message 1”, lowest priority is “User message 10”.

Display fonts

FD1600 has defined four usable fonts:

0 = Font 0, auto font selection
1 = Font 1, 8 x 10 pixel (normal)
2 = Font 2, 6 x 8 pixel (small)
3 = Font 3, 5 x 7 pixel (smaller)
4 = Font 4, 4 x 5 pixel (very small)

It is possible to select different font for static/steady texts (i.e. floors) and rolling texts.

Arrows

It is possible to enable both fixed arrows and moving (scrolling) arrows. Fixed arrows are usually used when display is mounted in the hall (floor 1-63). Moving arrows are usually used in the car (CAR1 and CAR2). It is possible to have both arrow types enabled at the same time (not preferred in HALL displays).

Both fixed and moving arrow use following arrow styles:

Style 0 Arrow with spike and tail (old style)

Style 1 6 LED rows, 12 dots wide (standard style flat spike)

Style 2 5 LED rows, 10 dots wide (standard style flat spike)

Style 3 4 LED rows, 8 dots wide (standard style flat spike)

Style 4 3 LED rows, 6 dots wide (standard style flat spike)

Style 5 2 LED rows, 4 dots wide (standard style flat spike)

Fixed arrows

Fixed arrows indicate direction of current travel, or intended direction of next travel.

Fixed arrows CAR

- 0 = Disabled
- 1 = Superimposed steady
- 2 = Superimposed flash
- 3 = Superimposed fade

Fixed arrows FLOOR

- 0 = Disabled
- 1 = Steady (enabled)

Fixed arrows, style

- 0 = Old style
- 1-5 = Solid arrow

Fixed arrows, position

- 0 = Automatic
- 1 = Middle
- 2 = Right
- 3 = Left
- 4 = Top
- 5 = Bottom

Moving arrows

The moving arrow normally have a much lower brightness than the floor names (text), resulting in a 3D effect. If preferred, the brightness can be set at a higher level.

Moving arrow

- 0 = Off
- 1 = CAR only
- 2 = FLOOR only
- 3 = both CAR and FLOOR

Moving arrow, style

- 0 = Old style
- 1-5 = Solid arrow

Moving arrow, position

- 0 = Automatic (standard)
- 1 = Middle
- 2 = Left
- 3 = Right

Boot menu

Holding down one of the menu buttons while power is connected displays a “boot menu”. The specific boot menu or function is selected when button is released. If button was pressed by mistake, release the button while unit show “RDY”, or keep pressing the button until display continues to normal working state (8-10 seconds).

“RDY”

The unit is ready and no changes are made. In lower line the current firmware version is shown.

“CFG”

Configuration is loaded from SD card, this can be used to copy a configuration from one unit to another.

“BTL”

Bootloader is activated.

“CLR ALL”

All parameters are cleared to factory defaults.

Arrival

Both arrival trigger and arrival sound is programmable. The arrival sound is heard on floor displays and SYS unit if used. No arrival sound on CAR units.

Trigger

It is possible to make arrival trigger on a number of events, but not all combinations make sense. As an example “CAR reduce” only make sense when using either external position device (IPS) or an encoder. “External input” only make sense if we also define and use an external input.

Sound

Some basic sounds are available if no SD card with sounds is used. If more sophisticated sounds are required, an SD card with sounds must be installed, and the sound setup must be performed by an external programming tool (computer or smartphone application).

Setup menu

If only one of the menu buttons is pressed, the menu for volume is entered directly. The volume can then be adjusted up or down as desired. If both buttons are pressed, the main menu is entered. When both buttons are pressed and a menu is already selected, the next submenu is shown. When end is reached (no more submenus), the main menu is shown again. If both buttons are pressed for 2 seconds in a submenu, the main menu is shown.

Menu buttons

“UP” = increase item / value / menu

“DOWN” = decrease item / value / menu

“ENTER” = both buttons pressed = accept value or enter menu/
sub-menu

“CANCEL” = both buttons pressed for 2 seconds

Configuration

Learning mode with IPS

The SLPro FD1600 need to be used in order to access all of the installation options.

Download SLPro from:
www.safeline-group.com

Learning is started with one of the following:

- Safeline LYNX app
- PC
- Menu buttons on the FD1600

1. Start the learning trip at the lowest level. Drive to the next level.
2. Make a stop at all levels. The position is saved automatically at each stop.
3. When the highest level is reached and the lift is changing direction, the learning trip is finished.
4. The IPS returns to normal functions.

Dynamic menus

Menu content change depending on selected values in "Unit" main menu.

Content change 1:

Main menu "Floor Text" only visible if "Main Mode" is not set to "Normal"

Content change 2:

Main menu "Learn" only visible if encoder or external position is selected as "Main Mode" (Unit / Main mode / Encoder)

Content change 3:

Main menu "Inputs" are only visible if all inputs are not predefined (e.g. if floor count is set to 8 and main mode is decimal, all inputs are predefined as individual floor generators).

Memory card

Expected directory structure:

X:\CFG = configuration directory

X:\WAV = wave files directory

X:\FIRMWARE = directory for firmware update

CFG directory

This directory holds a copy of the configuration, and also a copy of the sound index file.

WAV directory

This directory holds all sound files, including user sound files.

FIRMWARE directory

This directory is not in use yet.

Sound files

If the lift is travelling through sub-floors or basement, this naming is still used. The file "FLOOR 1.WAV" can of course say for instance: "Next stop basement"

All available sound files in all languages are packed together in the directory "WAV" on the SD card.

User sound files

If the user want to use own sound files, the files can be added by following these rules:

Floor announcement files are placed in directory \WAV\USER\FLOORS, and general message and other announcements are placed in directory: \WAV\USER\MESSAGES.

User floor files naming

User floor files are always named "FLOOR 1.WAV" to "FLOOR 63.WAV". If other names are used the files cannot be found by FD1600 NOTE: Space in floor 1

User message files naming

User general messages are always named "MESSAGE 1.WAV" to "MESSAGE 20.WAV". If other names are used the files cannot be found by FD1600.

Sound files requirements

FD1600 do support a limited number of sampling rates, and it is recommended to use 16kHz sampling / 16bit / MONO.

Checklist before deployment of IPS and FD1600

If you're having trouble with deployment - please call your local SafeLine support.

Please check the following before deployment:

- The display doesn't show ".T". When showing this, the IPS is conducting self tests. This can take up to 15 minutes after voltage is connected.
- The installation is wired according to wiring instructions.
- The termination switch 120 ohm on the FD1600 is activated (ON) at the beginning and end of the CAN BUS.

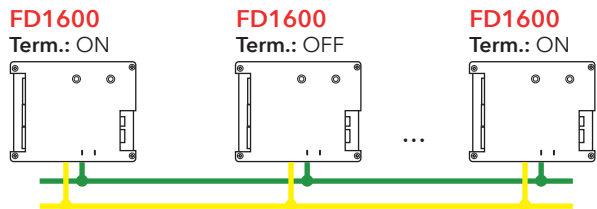

- In "Main Mode", the car unit should be programmed as "Ext. Position CAN".
- If the FD1600 has been installed on the floor levels, all of the floor units under the menu "UNIT ID" should be programmed as for instance Floor 1, Floor 2 etc.
- "Main Mode" must be set as "Normal".
- If voice messages are requested, the correct audio file need to be chosen on each respective floor in the car unit.
- The learning trip has been performed.

EU Declaration of Conformity

Product: Lift floor display
 Type / model: **FD1600**
 Article no: *FD1600-B, *FD1600-SPKREC-B, *FD1600-SPKSM-B
 *FD1600-R, *FD1600-SPKREC-R, *FD1600-SPKSM-R
 *FD1600-W, *FD1600-SPKREC-W, *FD1600-SPKSM-W
 Manufacturer: SafeLine Sweden AB
 Year: 2017

We herewith declare under our sole responsibility as manufacturer that the products referred to above complies with the following EC Directives:

Directives

Radio Equipment (RED):	2014/53/EU
RoHS 2:	2011/65/EU

Standards applied

EN 81-20:2014	Lift: Safety & Technical requirements
EN 81-50:2014	Lift: Test and examination requirements
EN 81-70:2003/A1:2004	Lift: Accessibility to lifts for persons including persons with disability
EN 12015:2014	EMC: Emission, Electromagnetic compatibility
EN 12016:2013	EMC/Lifts: Immunity, Electromagnetic compatibility
EN 62368-1:2014/AC:2015	LVD: Information Technology Equipment
EN 50581:2012	RoHS: Technical doc. for assessment of restriction of RoHS.

For RED 2014/53/EU, the conformity assessment procedure "Module A" used as described in Annex II. Accordingly, respective manufacturer has done the radio modules conformity assessment:

Module	Notified body	Address	NB nr	Test nr
CYW20732S	NTS Silicon Valley	41039 Boyce Road, Fremont, CA 94538, US	0214.26	R 104750/51

Standards applied

Article of Directive 2014/53/EU

EN 60950-1:2006+A11:2009+A12:2010+A12:2011	3.1 (a): Health and safety of the user
EN 62311:2008	
EN 301 489-1 V2.1.1 + EN 301 489-52v1.1.0 Draft	3.1 (B): Electromagnetic Compatibility
EN 301 489-17 V3.1.1	
EN 300 328 V2.1.1	3.2: Effective use of spectrum allocated

Firmware used during assessment

SafeLine FD1600:	1.00
------------------	------

Tyresö, 2017-04-07

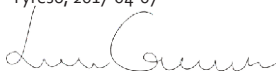

Lars Gustafsson,
 Technical Manager, R&D, SafeLine Group

**SafeLine Headquarters**

Antennvägen 10 · 135 48 Tyresö · Sweden
Tel.: +46 (0)8 447 79 32 · info@safeline.se
Support: +46 (0)8 448 73 90

SafeLine Denmark

Vallensbækvej 20A, 2. th · 2605 Brøndby · Denmark
Tel.: +45 44 91 32 72 · info@safeline.dk

SafeLine Norway

Solbråveien 49 · 1383 Asker · Norway
Tel.: +47 94 14 14 49 · post@safeline.no

SafeLine Europe

Industrieweg 114 · 3980 Tessenderlo-Ham · Belgium
Tel.: +32 (0)13 664 662 · info@safeline.eu
Support: +32 (0)4 85 89 08 95

SafeLine Deutschland GmbH

Kurzgewannstraße 3 · D-68526 Ladenburg · Germany
Tel./Support: +49 (0)6203 840 60 03 · sld@safeline.eu

SafeLine Group UK

Unit 47 · Acorn Industrial Park · Crayford ·
Kent · DA1 4AL · United Kingdom
Tel.: +44 (0) 1322 52 13 96 · info@safeline-group.uk

SafeLine is a registered trademark of SafeLine Sweden AB. All other trademarks, service marks, registered trademarks, or registered service marks are the property of their respective owners.